

***SAFETY
VALVE***

***4000
SERIES***

***USE AND
MAINTENANCE
MANUAL***

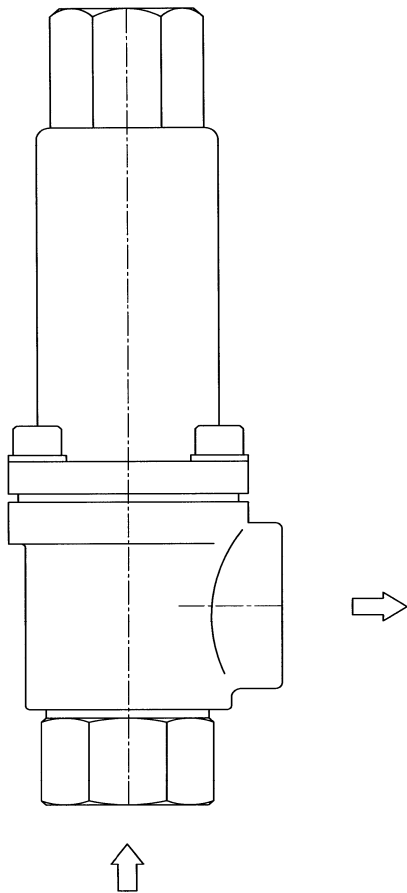

SAFETY VALVE FOR LIQUID SERVICES

Characteristics

- Overpressure 10%;
- blowdown 10%;
- spring range $\pm 10\%$ of set pressure;
- liquid discharge coefficient $k= 0,6$;
- connections : ANSI, UNI, DIN, etc.

Accessories

- Test gag ;
- soft seat ;
- balancing bellows ;
- heating jacket.

CHARACTERISTICS AND PRESSURE LIMITS

Type DN	Orifice		Lift mm	Max. set pressure bar	Max. backpressure	
	\varnothing mm	Area cm ²			without bellows bar	with bellows bar
3/8"	15	0,4	0,9	10	10	10
3/8"	15	0,4	1,1	107	19	10
3/8"	11	0,4	1,5	400	28	10
1/2"	15	0,8	1,7	10	10	10
1/2"	15	0,8	2,2	107	19	10
1/2"	11	0,4	1,5	400	28	10
1"	22	2,1	3,8	60	10	10
1"	15	0,8	2,2	107	19	10
1"	11	0,4	1,5	235	28	10
1 1/2"	32	4,5	4,8	32	10	10
1 1/2"	30	3,9	5,2	88	19	10
2"	38	6,5	6,9	32	10	10
2"	30	3,9	5,2	88	19	10

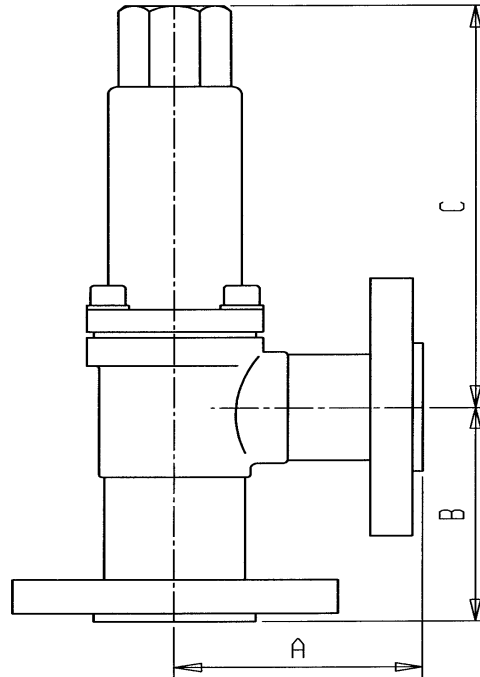
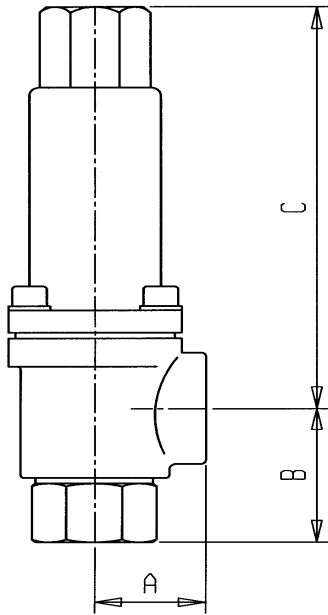

Pump capacity simplex duplex triplex max. l/h	Orifice	Set pressure	Valve connections	Inlet flange	Outlet flange	Dimensions mm			Weight approx
	min. disch. area			ANSI	ANSI	A	B	C	Kg.
	Dia. Ø = mm Area A = cm ²	max. bar	DN mm	UNI PN	UNI PN				
200 400 600	Ø = 11 A = 0,4	15 PVC 400 ST.STEEL	3/8" 10	GAS / NPT 40 64 ÷ 400	GAS / NPT 40 40	32 70 70	47 70 80	150 150 150	2,5 4,5 6,5
400 800 1200	STANDARD Ø = 15 A = 0,8	12 PVC 100 ST.STEEL	1/2" 15	GAS / NPT 150 ÷ 600 40	GAS / NPT 150 ÷ 300 40	32 70	47 70	150 150	2,5 5
	REDUCED Ø = 15R A = 0,4	400 ST.STEEL		1500 64 ÷ 320 2500 250	300 40 300 40	70 90 95	150 150	6,5 8	
1200 2400 3600	STANDARD Ø = 22 A = 2,1	9 PVC 40 ST.STEEL	1" 25	GAS / NPT 150 ÷ 600 40	GAS / NPT 150 ÷ 300 40	42 * (48 * PVC) 88	57 80	165 165	4 8
	REDUCED Ø = 15 A = 0,8	100 ST.STEEL		900 64 ÷ 160 2500 400	300 40 300 40	88 110 110	165 165	10 12	
3600 7200 10800	Ø = 32 A = 4,5	6 PVC 40 ST.STEEL	1 1/2" 40	GAS / NPT 150 ÷ 600 40	GAS / NPT 150 ÷ 300 40	56 * (65 * PVC) 107	71 90	215 260	9 16
7000 14000 21000	Ø = 38 A = 6,5	5 PVC 30 ST.STEEL	2" 50	GAS / NPT 150 ÷ 300 40	GAS / NPT 150 ÷ 300 40	70 130	75 90	220 260	11 19

The max. capacity is calculated for water at 4° C, with 2 ÷ 3 m/sec max velocity and DP min. of 1,5 kg/cm².

4000 SERIES SAFETY VALVE

The valve of **4000 Series** are particularly suitable for use as maximum pressure and back-pressure valves for reciprocating metering pumps.

They are full nozzle and flat seat type, with closed bonnet and spring insulated by a seal ring.

The body and the bonnet of 3/8"-1/2" stainless steel valves are obtained from precision casting.

The valves are produced in metal materials (carbon steel, stainless steel, super alloy, etc.), and in plastic materials (PVC, Polypropylene, Pffe, etc.) suitable for aggressive liquids.

Valves are available with threaded connections (GAS or NPT) and flanged connections (UNI-DIN or ANSI).

A special version with heating jacket, insulating bellows and incorporated flanges is provided for special applications, for example for viscous or heated liquids.

1. INSTALLING

Before installing the valve on the plant make sure that:

- the line fluid is indicated on the construction declaration or is suitable with what stated in it;
- the inlet piping of the valve is devoid of impurities, slag etc. and eventually remove them;
- the inlet and discharge piping are dimensioned in such a way that they generate the minimum possible loss of pressure.

In case the valve that is going to be installed is a **threaded type** use for tightening the key of the nozzle (1); if the valve is a **flanged type** tighten the bolts in a uniform way.

Once the valve has been installed on the plant make sure that:

- the discharge is not positioned in such a way to result dangerous for people or for instruments;
- the discharge is properly conveyed.

1.1 SETTING UP

Before shipment all the safety valves are hydrostatically tested and set at the setting pressure required by the Client. Therefore regulation in loco should be necessary.

The maximum setting error is less than 3% for pressure up to 21 bar, with a minimum of 0,2 bar; it is less than 0,7 bar up to 70 bar; it is less than 1% for pressure over 70 bar.

In case it should be necessary to modify the set pressure or the re-closure pressure of the valve (blowdown) , it should be necessary proceed as follows:

1.1.1 setting regulation (referring to drawing)

In order to carry out setting regulation of the valve it is necessary:

- remove the cap (15) and unloosen the lock nut (17);
 - turn the adjusting screw (12) clockwise in case the set pressure should be increased ;
 - turn the adjusting screw (12) counter-clockwise in case the set pressure should be decreased.
- The adjustment range of the spring setting is $\pm 10\%$ of the set pressure indicated on the label of the valve. Once the valve setting is regulated tighten the lock nut (17) and re-screw the cap (15).

2. DISASSEMBLING

2.1 VALVE WITHOUT ACCESSORIES

In order to execute disassembling carry out progressively the following operations:

CAUTION : before disassembling the valve make sure that the plant on which it is mounted is not "under pressure" and that no pressure inside the valve itself has remained.

- remove the valve from the plant ;
- remove the cap (15) and unloosen the lock nut (17) and the adjusting screw (12);

CAUTION : before disassembling the bonnet of the valve body make sure that the spring (11) is totally released using the adjusting screw (12).

- remove the screw (18), the bonnet (14) and extract all the internal parts;
- remove the nozzle (1).

2.2 VALE WITH SOFT SEAT

In order to execute disassembling carry out progressively the following operations:

CAUTION : before disassembling the valve make sure that the plant on which it is mounted is not "under pressure" and that no pressure inside the valve itself has remained.

- remove the valve from the plant ;
- remove the cap (15) and unloosen the lock nut (17) and the adjusting screw (12);

CAUTION : before disassembling the bonnet of the valve body make sure that the spring (11) is totally released using the adjusting screw (12).

- remove the screw (18), the bonnet (14) and remove all internal parts;
- remove the bell (20) from the disc (2) and remove the gasket (21);
- remove the nozzle (1).

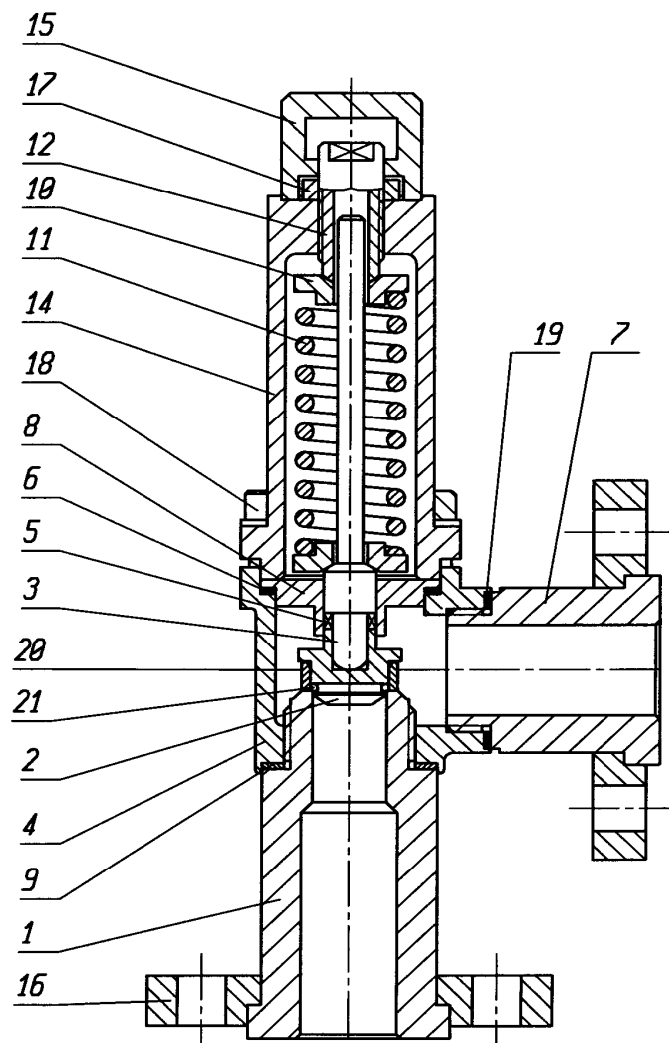
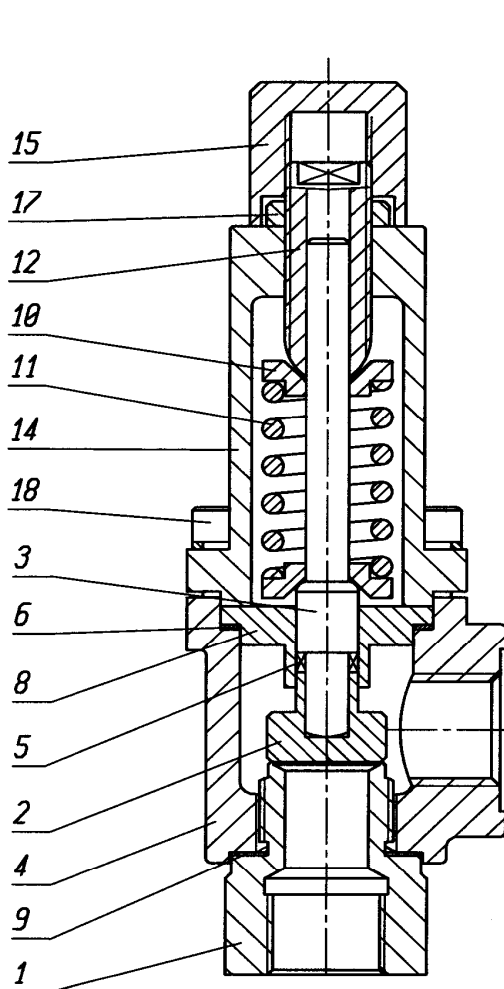

3. ASSEMBLING

3.1 VALVE WITHOUT ACCESSORIES

For assembling carry out the same operations of point **2.1**) but in reverse order , tightening first the nozzle (1) to the body (4); mounting the internal parts inserting firstly, from the convex part, the seal ring (5) in the guide (8) and only secondly the stem (3) and the disc (2).

3.2 VALVE SOFT SEAT

For assembling carry out the same operations of point **2.2**) but in reverse order , tightening first the nozzle (1) to the body (4); mounting the gasket (21) the bell (20) ,on the disc (2) later mounting the internal parts inserting firstly, from the convex part, the seal ring (5) in the guide (8) and only secondly the stem (3) and the disc (2).

4. MAINTENANCE

The safety valves requires an ordinary but careful maintenance (**SEE MAINTENANCE PLANT**) and in case it would be necessary , follow the operation stated in point **2**) for disassembling and in point **3**) for assembling.

In case of seats damaging it is necessary to carry out a new lapping: this operation has to be executed by skilled workers.

In case inconvenience should occur to the valve, verify if in the **DAMAGES TABLE** are contained some useful instructions for solving the problem.

In case the inconvenience is of different nature from what stated in the table, contact our Service Dept.

WARNING

- The safety valves should not be subjected to bumps or such stresses that could compromise the working.
- High loads on the spring can damage the valve.
- The safety valve must be used only exclusively for the use stated in the construction declaration.
- The safety valve must be revised within two years from installation independently from the number of interventions executed by the valve.

ACCESSORIES

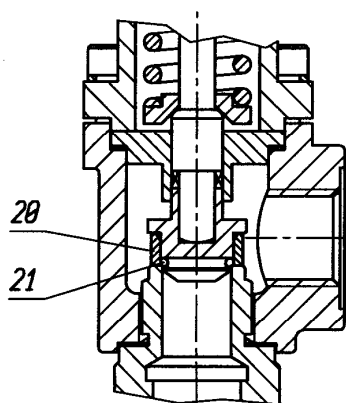

SOFT SEAT

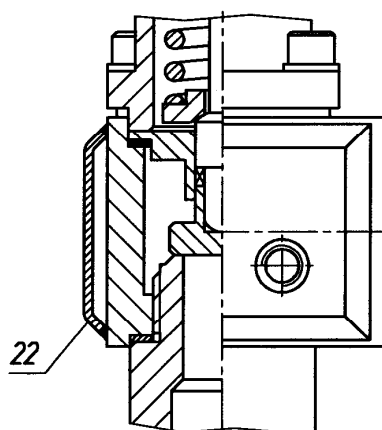

JACKET

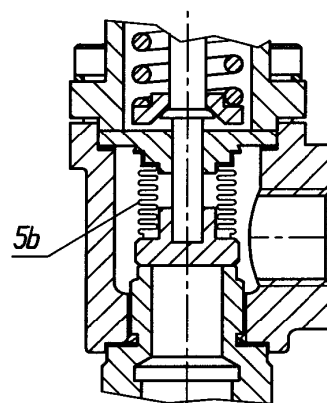

BELLOWS

ORDINARY MAINTENANCE PLAN	
Check of the seat and disc on the plant	Every valve opening or every 6 months working.
Check of the seal outwards in case of back pressure on the plant	Every 30 days.
Check of the painting condition on the plant.	Every 6 months.
Ordinary maintenance of the assembled on the plant, including the seal check and surface check of the movable components.	Every 12 months working.
General maintenance of the valve removed from the plant including the disassembling, the seat and the disc check, the possible seat and disc lapping, gaskets substitution, painting restoration and inspection on the test bench.	Every opening with seats damaging or every 24 months working.

DAMAGES TABLE		
INCONVENIENT	POSSIBLE DAMAGE	ACTION TO BE CARRIED OUT
Fluid leakage in line	Sea wear and tear	Nozzle substitution or revision
	Disc wear and tear	Disc substitution or revision
	Seat and disc damaging	Nozzle and disc revision
	Impurities presence between seat and disc	Nozzle and disc cleaning and revision
	Valve used with fluid different from the one stated in the purchase order	Nozzle and disc revision
External back pressure fluid leakage	Bellows breakage	Bellows substitution
	Valve gasket damaging	Gasket substitution
	Valve body and bonnet damaging	Valve revision or substitution
	Cap loosen	Check and setting up of the cap.
Opening at pressure value different from setting valve	Back pressure changeable	Check of dimensioning and of the discharge piping working conditions and possible valve substitution with another balanced type.
	Spring release	Spring substitution and check compatibility of the material with the fluid.
	Setting screw withdraw	Resetting the valve and tighten very well the lock .nut
Valve intervention with quick opening and re-closures repeated in the time	Strong loss load in the inlet piping	Check the inlet piping length
	Pulsating flow rate to be discharge	Check plant regulation..
	Over-dimensioned valve	Substitute the valve with one correctly dimensioned.

MATERIAL TABLE SAFETY VALVE 4000 SERIES

Wetted parts								
Note	ITEM	PARTICULAR	16 (1)	60 (2)	6X	76	81	85
	1	NOZZLE	AISI 316	AISI 316	AISI 316	HASTELLOY-C	PVC	PTFE+GLASS
	2	DISC	AISI 316	AISI 316	AISI 316	HASTELLOY-C	PTFE	PTFE
6	3	STEM	AISI 303	AISI 303	AISI 316	HASTELLOY-C	PVC	PTFE+303
7	4	BODY	CARB.STEEL	AISI 316	AISI 316	HASTELLOY-C	PVC	PTFE+GLASS
	5	SEAL RING	PTFE+316	PTFE+316	PTFE+316	PTFE+HAST.	PTFE+HAST.	PTFE+HAST.
	5b	BELLOWS	AISI 316L	AISI 316L	AISI 316L	HASTELLOY-C	PTFE	PTFE
3	6	GUIDE GASKET	PTFE	PTFE	PTFE	PTFE	PTFE	PTFE
	7	NIPPLE	CARB.STEEL	AISI 316	AISI 316	HASTELLOY-C	PVC	PTFE+GLASS
	8	GUIDE	AISI 303	AISI 303	AISI 316	HASTELLOY-C	PVC	PTFE
3	9	NOZZLE GASKET	PTFE	PTFE	PTFE	PTFE	PTFE	PTFE
Insulated parts								
	10	SPRING GUIDE	CARB.STEEL	CARB.STEEL	CARB.STEEL	CARB.STEE L	CARB.STEE L	CARB.STEE L
			AISI 303	AISI 303	AISI 303	AISI 303	AISI 303	AISI 303
	11	SPRING	ALLOY ST.	ALLOY ST.	ALLOY ST.	ALLOY ST.	ALLOY ST.	ALLOY ST.
			AISI 316	AISI 316	AISI 316	AISI 316	AISI 316	AISI 316
	12	ADJUSTING SCREW	AISI 303	AISI 303	AISI 303	AISI 303	PVC	PVC
	13	BONNET FLANGE	AISI 304	AISI 304	AISI 304	AISI 316	AISI 304	AISI 304
5	14	BONNET	CARB.STEEL	CARB.STEEL	AISI 316	AISI 316	PVC	PVC
4	15	CAP	PVC	PVC	AISI 303	AISI 303	PVC	PVC
	16	IN/OUT FLANGE	ACC.CARB.	ACC.CARB.	AISI 316	AISI 316	CARB.STEE L	AISI 316
	17	LOCK NUT	AISI 303	AISI 303	AISI 303	AISI 303	AISI 303	AISI 303
	18	SCREW	AISI 304	AISI 304	AISI 304	AISI 304	AISI 304	AISI 304
	19	NIPPLE GASKET	PTFE	PTFE	PTFE	PTFE	PTFE	PTFE
	20	BELL	PTFE	PTFE	PTFE	PTFE	PTFE	PTFE
8	21	O-RING	FPM RUBBER	FPM RUBBER	FPM RUBBER	FPM RUBBER	FPM RUBBER	FPM RUBBER
	22	JACKET	ST.STEEL	ST.STEEL	ST.STEEL			

Note :

- 1** Available with stellited seat - codice **H6**
- 2** Available with stellited trim - codice **6K**
- 3** For all valves with heating jacket gaskets are in **Aramidic Fibre**.
- 4** For valves in class 16 and 60 with heating jacket, the cap is in **AISI 303**.
- 5** For 3/8"-1/2" valves, the bonnet is integral with the bonnet flange.
- 6** For valves in 76 class with isolating bellows, the stem is in **AISI 303**.
- 7** For 3/8"-1/2" valves in 16 and 60 class, the body is in **AISI 316**.
- 8** In the valves with soft seat, depending on the fluid characteristics, the o-ring can be supplied also in other material.